

Transforms the rectilinear motion of two single acting opposite cylinders into rotary motion via a rack and pinion drive contained within the cylinder body.



- VRA version (Ø32 to Ø80mm)
- VRA standard version (Ø32 to Ø125mm) for corrosive environments
- Rotation angles of 96°, 186° or 366°
- Optional magnetic version
- Several options are available; rotative angle adjustable stop, male shaft or female shaft (through)

Operating information

Working pressure: Max, 10 bar
Standard working temperature: -10°C to +60°C

Prelubricated, further lubrication is not normally necessary. If additional lubrication is introduced it has to be continued.

VRA - Magnetic, Female shaft, No end adjustment

Bore	Rotation Angle (°)	Order code	Bore	Rotation Angle (°)	Order code	Bore	Rotation Angle (°)	Order code
32	96	VRAM032-96FNN	50	96	VRAM050-96FNN	80	96	VRAM080-96FNN
32	186	VRAM032-186FNN	50	186	VRAM050-186FNN	80	186	VRAM080-186FNN
32	366	VRAM032-366FNN	50	366	VRAM050-366FNN	80	366	VRAM080-366FNN
Bore	Rotation Angle (°)	Order code	Bore	Rotation Angle (°)	Order code			
40	96	VRAM040-96FNN	63	96	VRAM063-96FNN			
40	186	VRAM040-186FNN	63	186	VRAM063-186FNN			
40	366	VRAM040-366FNN	63	366	VRAM063-366FNN			

VRS - Magnetic, Female shaft, No end adjustment

Bore	Rotation Angle (°)	Order code	Bore	Rotation Angle (°)	Order code	Bore	Rotation Angle (°)	Order code
32	96	VRSM032-96FNN	63	96	VRSM063-96FNN	125	96	VRSM125-96FNN
32	186	VRSM032-186FNN	63	186	VRSM063-186FNN	125	186	VRSM125-186FNN
32	366	VRSM032-366FNN	63	366	VRSM063-366FNN	125	366	VRSM125-366FNN
Bore	Rotation Angle (°)	Order code	Bore	Rotation Angle (°)	Order code			
40	96	VRSM040-96FNN	80	96	VRSM080-96FNN			
40	186	VRSM040-186FNN	80	186	VRSM080-186FNN			
40	366	VRSM040-366FNN	80	366	VRSM080-366FNN			
Bore	Rotation Angle (°)	Order code	Bore	Rotation Angle (°)	Order code			
50	96	VRSM050-96FNN	100	96	VRSM100-96FNN			
50	186	VRSM050-186FNN	100	186	VRSM100-186FNN			
50	366	VRSM050-366FNN	100	366	VRSM100-366FNN			

For more options consult technical catalogue

Dimensions (mm)

Cylinder bores Ø 32 to 80mm

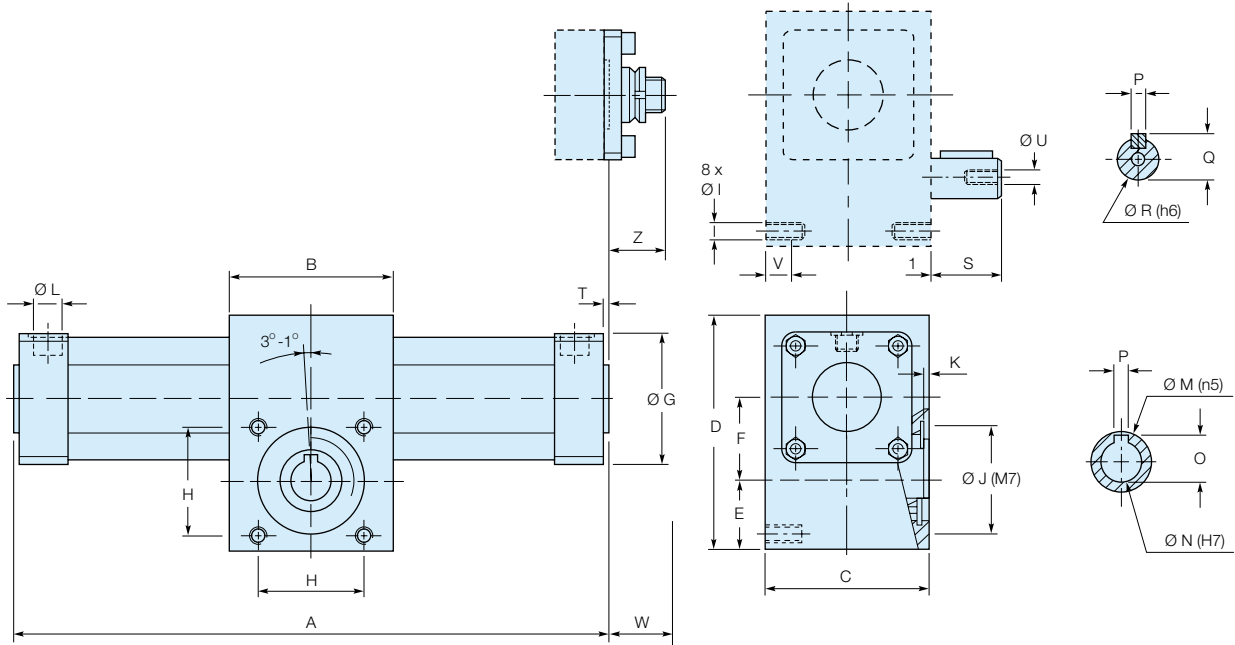

The location of the shaft key is indicated when the pistons are on the left.
First rotation as indicated (clockwise).

Ω : Rotative angle 96°, 186° or 360°

Ø	A*	B	C	D	E	F	G	H	I	J	K	L
32	128 + 0.523 Ω	50	50	72	25.0	24.0	45	35	M6	35	2.0	G1/8"
40	163 + 0.6981 Ω	65	65	95	32.5	29.5	52	47	M8	47	3.0	G1/4"
50	163 + 0.6981 Ω	65	65	95	32.5	29.5	65	47	M8	47	3.0	G1/4"
63	209 + 0.9424 Ω	95	95	126	40.0	38.0	75	62	M10	62	3.5	G3/8"
80	209 + 0.9424 Ω	95	95	126	40.0	38.0	95	62	M10	62	3.5	G3/8"

Ø	M	N	O	P	Q	R	S	T	U	V	W*	Z
32	17	10	11.7	4	13.5	12	20	2	M4 x 10	10	22	31
40	25	15	17.2	5	18.0	16	30	3	M5 x 15	12	24	35
50	25	15	17.2	5	18.0	16	30	3	M5 x 15	12	29	35
63	35	24	27.2	8	27.0	24	40	3	M8 x 20	15	32	32
80	35	24	27.2	8	27.0	24	40	3	M8 x 20	15	32	32

* Add W to A for the magnetic version (magnet on right hand side as standard).

Dimensions (mm)

Cylinder bores Ø 100 to 125mm

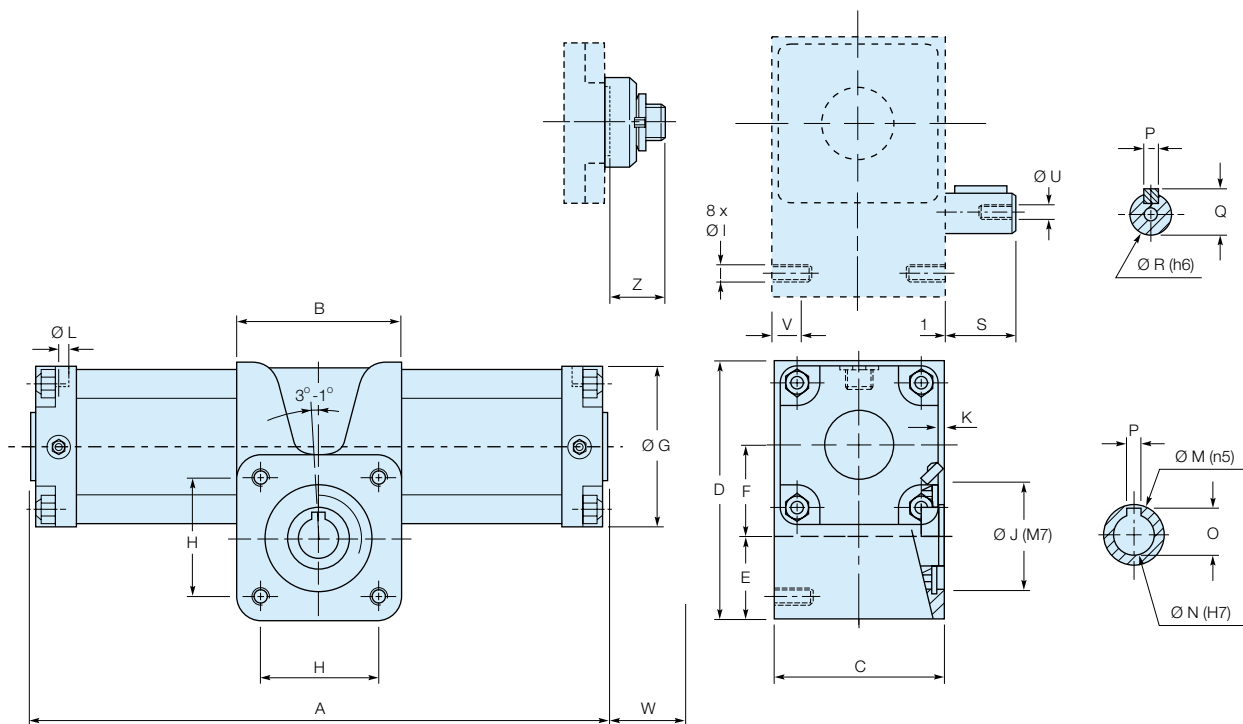

The location of the shaft key is indicated when the pistons are on the left.
First rotation as indicated (clockwise).

Ω : Rotative angle 96°, 186° or 360°

Ø	A*	B	C	D	E	F	G	H	I	J	K	L
100	304 + 1309 Ω	130	142	188	64.0	53.5	115	90	M14	90	4.5	G1/2"
125	304 + 1309 Ω	130	142	188	64.0	53.5	140	90	M14	90	4.5	G1/2"
Ø	M	N	O	P	Q	R	S	U	V	W*	Z	
100	55	35	38.7	10	38.5	35	50	M12 x 20	24	4	38	
125	55	35	38.7	10	38.5	35	50	M12 x 20	24	4	38	

* Add W to A for the magnetic version (magnet on right hand side as standard).

Material specification

	VRS	VRA
Rack	XC40 steel	XC40 steel
Floating piston	Aluminium	Aluminium
Magnet (**M version)	Magnetic elastomer	Magnetic elastomer
Piston seals	Polyurethane	Polyurethane
Rack and pinion gear seals		Silicone
Body	Anodised aluminium	Anodised aluminium
Integrated tie rods, nuts, circlips, screws	Zinc plated steel	303 stainless steel
Body	Hard anodised aluminium extrusion	Hard anodised aluminium extrusion
End caps	Anodised aluminium	Anodised aluminium
Male or female transmission shaft	XC40 steel	304 stainless steel (female)
Cushion sleeve	Brass	Brass
Clearance adjusting block (Ø 32 to 80mm)	Acetal	Acetal
Adjusting screw blanking plate		Aluminium + silicone seal

Condition of use

	Ø 32 to 80mm	Ø 100 and 125mm
Temperature range	-10°C to +60°C (14°F to 140°F)	
Pressure range (bar)	0.5 to 10 7 to 145 psi)	0.3 to 10 (4 to 145 psi)
Air condition	Filtered air 40µ, lubricated or non lubricated, dry or non dry	

Theoretical torque

Ø Bore 10 bar	Pinion mm	Module	ØPm	Torque (N.m)			
				2 bar	4 bar	6 bar	8 bar
32	1.5	20	2.4	4.8	7.2	9.6	12
40	2	40	5.0	10.0	15.0	20.0	25
50	2	40	8.0	16.0	24.0	32.0	40
63	3	54	17.0	34.0	51.0	68.0	85
80	3	54	27.0	54.0	81.0	108.0	135
100	5	75	58.0	116.0	174.0	232.0	290
125	5	75	92.0	184.0	276.0	368.0	460

The table above shows the theoretical torque at different pressures. A maximum efficiency of 80% should be assured due to functional losses.

Technical data

Bore (mm)		32	40	50	63	80	100	125
Maximum load (N)	Axial	110	350	350	1050	1050	2500	2500
	Radial	35	220	220	900	900	2000	2000
Cushion angle (°)		50	45	45	32	32	30	30
Nominal moment of inertia (kg.m ²)		0.003	0.01	0.02	0.1	0.2	0.3	0.4
Rotative angle (-1°)		96°, 186°, 366°						
Angular tolerance		0°10'	0°10'	0°10'	0°10'	0°10'	1°	1°